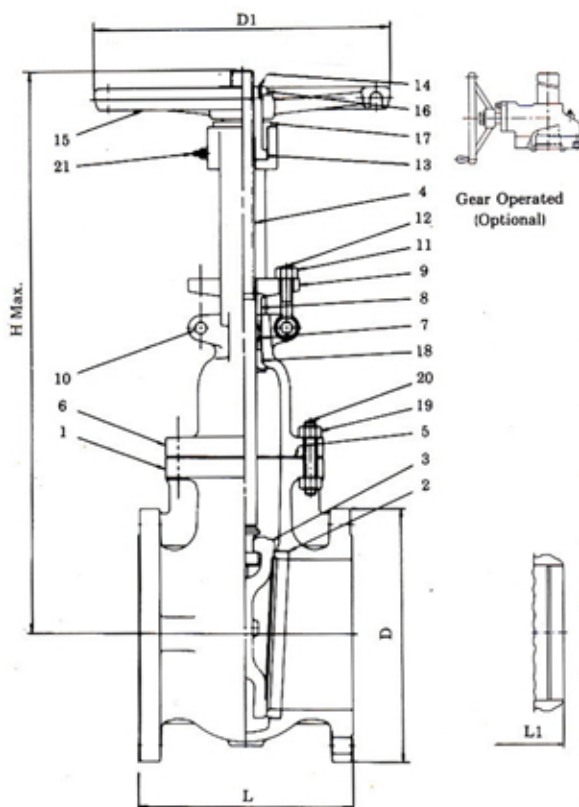



Fig. 111



CAST STEEL GATE VALVE CLASS 150

FIGURES: 111, 111B
DESIGN DESCRIPTION:

Bolted Bonnet
Outside Screw and Yoke
Flexible Wedge,
Rising Stem and Non-Rising
Handwheel
Oval Bonnet with Integral Yoke
(But 14" and Larger are Separated)
Renewable Seat Rings
Available with By-Pass
Flanged Ends (Fig.111)
Buttwelding Ends (Fig.111B)

APPLICABLE CLASS 150
STANDARDS:

Steel Gate Valves, API 600
Steel Valves, ANSI B16.34
Face to Face, End to End, ANSI
B16.10

End Flanges, ANSI B16.5
Weld Ends, ANSI B16.25

TEST PRESSURE:

Shell (by Water), 450psig
Seat (by Water), 315psig
(by Air), 60-100psig

PARTS AND MATERIAL LIST

Part No.	Parts Name	Materials
1	Body	ASTM A216-WCB
2	Seat Ring	ASTM A106 - B/A105 + H/F STL#6
3	Disc (4" and larger) (1½" to 3")	ASTM A216-WCB+H/F410 ASTM A217-CA15
4	Stem	ASTM A182-F6a Class 2
5	Gasket	Soft Iron / NOVA PRESS #300
6	Bonnet	ASTM A216-WCB
7	Gland Packing	GARLOCK 127 AFP OR EQU.
8	Gland	MPIF35-304N2-33 / ASTM A276-410
9	Gland Flange	ASTM A216-WCB/A181
10	Eye Bolt Pin	ASTM A36
11	Eye Bolt Nut	ASTM A194-2H
12	Eye Bolt	ASTM A307-B
13	Yoke Sleeve	ASTEM A439-D2
14	Set Screw	ASTM A193-B6
15	Hand Wheel	ASTM A536 (65-45-12)
16	Hand Wheel Nut	ASTM A536 (65-45-12)
17	Yoke Sleeve Nut	ASTM A536 (65-45-12)
18	Bonnet Bush	ASTM A276-410
19	Bonnet Bolt Nut	ASTM A194-2H
20	Bonnet Bolt	ASTM A193-B7
21	Nipple	Carbon Steel

DIMENSIONS IN INCHES:

SIZE	1½	2	2½	3	4	5	6	8	10	12	14	16	18	20	24
D	5	6	7	7½	9	10	11	13½	16	19	21	23½	25	27½	32
L	6½	7	7½	8	9	10	10½	11½	13	14	15	16	17	18	20
L1	6½	8½	9½	11¼	12	15	15¾	16½	18	19¾	22½	24	26	28	32
H (OPEN)	14¼	15½	16 ²⁷ / ₃₂	18 ⁹ / ₁₆	23 ²¹ / ₃₂	27 ²¹ / ₃₂	31 ¹¹ / ₃₂	39¼	46 ²¹ / ₃₂	54 ¹³ / ₁₆	61 ³ / ₃₂	68 ⁷ / ₈	76 ¹³ / ₁₆	85 ¹⁷ / ₃₂	101 ⁷ / ₈
H (CLOSE)	12½	13 ¹ / ₃₂	13 ⁷ / ₈	15 ³ / ₃₂	18 ²³ / ₃₂	22 ¹ / ₁₆	24 ²¹ / ₃₂	30 ¹⁷ / ₃₂	36 ¹ / ₁₆	42 ²¹ / ₃₂	46 ²⁹ / ₃₂	52 ²¹ / ₃₂	58 ¹³ / ₃₂	65 ¹ / ₈	76 ²⁹ / ₃₂
D1	8	8	8	8	10	13	14	16	18	20	22	24	27	30	30
wt.(111),lbs.	36	46	56	71	111	163	196	289	449	639	860	1190	1389	1786	2601
wt.(111B),lbs.	28	40	46	58	91	152	180	259	425	584	811	1146	1499	1720	2646

NOTE: JINN LUNG RESERVES THE RIGHT TO CHANGE DESIGNS, MATERIALS OR SPECIFICATIONS WITHOUT NOTICE