

MK Water Gun

MK

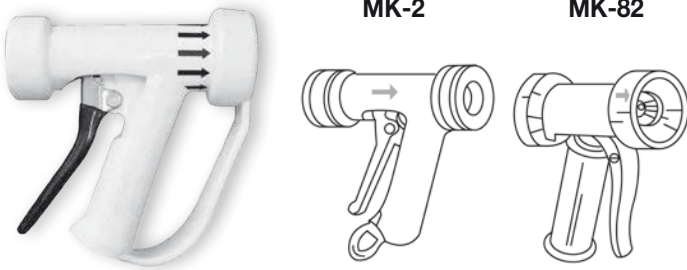

Model	Material	Rubber Cover	Trigger	Orifize Size		Maximum Pressure	
				in	mm	MPa	psi
MK-2	Gunmetal or Stainless Steel	Black or White	rear	5/16"	7,9	2,8	406,0
MK-OH				7/16"	11,1		
MK-MV				9/16"	14,3	0,7	101,5
MK-78	Gunmetal	Black or White	front	5/16"	7,9	1,4	203,0
MK-80				7/16"	11,1		
MK-82				9/16"	14,3	0,7	101,5

Pressure		Orifize Size			Orifize Size		
		5/16"	7/16"	9/16"	5/16"	7/16"	9/16"
MPa	psig	l/min			GPM		
0,035	5,0	3,2	13,5	15,0	0,84	3,56	3,96
0,07	10,2	5,6	20,0	21,0	1,48	5,28	5,54
0,1	14,5	7,0	22,5	24,0	1,85	5,94	6,34
0,2	29,0	10,0	25,0	36,0	2,64	6,60	9,50
0,3	43,5	12,5	32,0	47,0	3,30	8,45	12,41
0,35	50,8	14,5	37,0	52,0	3,83	9,77	13,73
0,4	58,0	16,0	38,0	55,0	4,22	10,03	14,52
0,5	72,5	18,0	40,0	60,0	4,75	10,56	15,84
0,6	87,0	20,5	42,0	65,0	5,41	11,09	17,16
0,7	101,5	22,3	44,0	69,0	5,89	11,62	18,22
1,0	145,0	27,5	51,0	-	7,26	13,46	-
1,5	217,5	35,0	62,0	-	9,24	16,37	-
2,0	290,0	43,0	74,0	-	11,35	19,54	-
2,5	362,5	50,5	85,0	-	13,33	22,44	-

Features

1. Trigger operated water gun. Front trigger or rear trigger available
2. Perfect water consumption control
3. One-handed mode with either variable spray or direct jet
4. Automatic and immediate shut-off when the trigger is released

Suitable for

MK2 is suitable for most industrial applications
MK-MV is recommended for use with Steam-Water-Mixing Valves

CVC3, CVC3R, CV5R Check Valve

CVC3, CVC3R, CV5R



Pressure Drop Chart

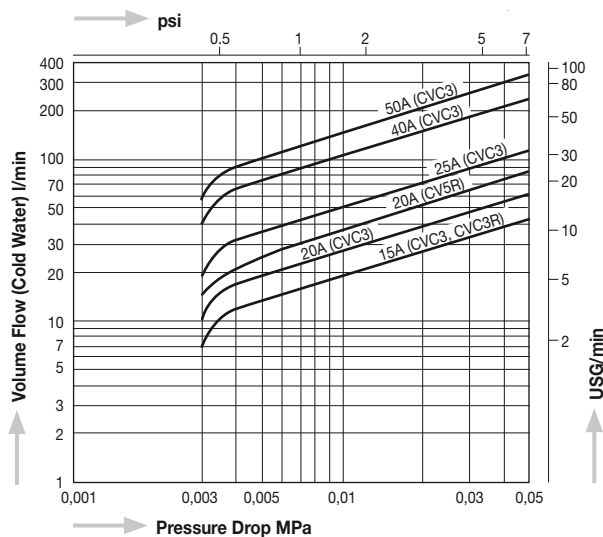

Dimensions

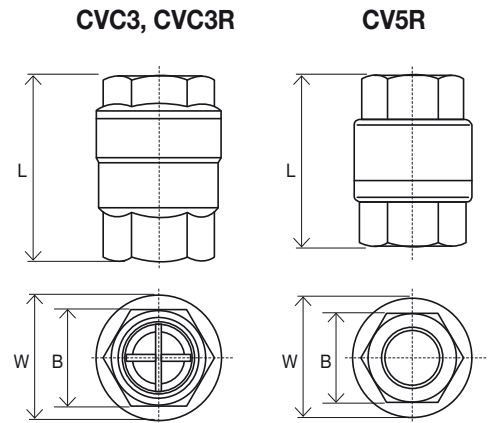

Model	Connections	Size (in)	Max. Operating Pressure		Opening Pressure		Max. Operating Temperature		Dimensions (mm)			Dimensions (in)			Body Material	Weight	
			MPa	psig	MPa	psig	°C	°F	L	W	B	L	W	B		kg	lb
CVC3	Screwed Rc, NPT	1/2"	2,1	305	0,003	0,44	220	428	48	35	27	1,9	1,4	1,1	Stainless Steel SCS13A	0,2	0,44
		61							43	33	2,4	1,7	1,3	0,3		0,66	
		73							54	41	2,9	2,1	1,6	0,6		1,32	
		87							75	58	3,4	3,0	2,3	1,2		2,64	
		100							90	72	3,9	3,5	2,8	1,8		3,96	
CVC3R	Screwed Rc, NPT	1/2"	2,1	305	0,003	0,44	80	176	48	35	27	1,9	1,4	1,1	SCS13A	0,2	0,44
CV5R	Screwed Rc, NPT	3/4"	1,6	230	0,003	0,44	80	176	60	40	34	2,4	1,6	1,3	SCS13A	0,3	0,66